

#### IV ème République



Vincent Auriol  
1947-1954



René Coty  
1954-1958

#### Vème République



Charles de Gaulle  
1958-1965  
Elu au suffrage universel direct en  
1965  
Seconde présidence : 1966-1969



Georges Pompidou  
1969-1974



Valéry Giscard d'Estaing  
1974-1981



François Mitterrand  
Premier septennat : 1981-1988  
Second septennat : 1988-1995



Jacques Chirac  
Septennat : 1995-2002  
Quinquennat : 2002-2007



Nicolas Sarkozy  
2007-2012



François Hollande  
2012-

50 le style international

60/70 les années Pop

80 la postmodernité

90/2000 3 tendances

50'

Action painting



Elegy to the Spanish Republic, Robert Motherwell, 1958



De Kooning, Woman, 1952



All over, Jackson-Pollock

Expressionnisme abstrait  
L'école de New York

Colorfield



Colorfield, Rothko, n°8, 1952



Concord, 1949, Barnett Newman

30'

Le Streamline  
« La beauté par la fonction et la simplification »



La Laideur se vend mal

40'



États Unis

Raymond Loewy

Le père du design industriel

50'

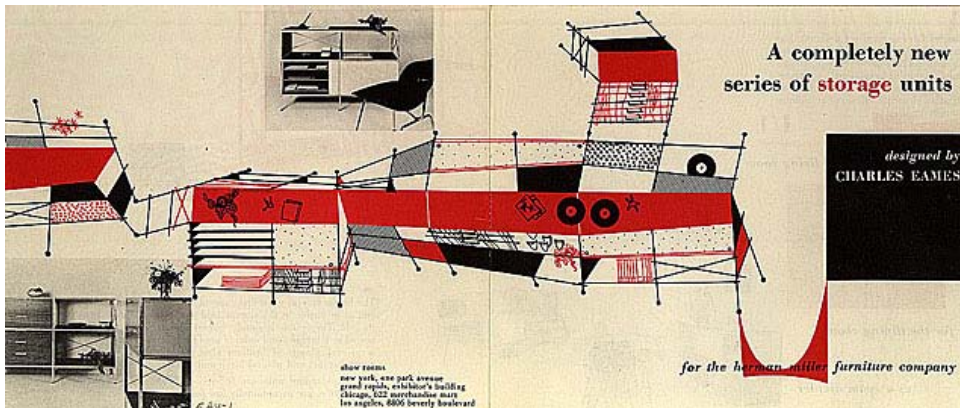

Case Study House #8, 1951,  
Pacific Palisades, California

# Japon

Isamu Noguchi

Sori Yanagi



Tabouret Butterfly, contreplaqué moulé, 1954

Lampe de sol "Akari"  
Table basse, 1951



Charlotte Perriand

Chaise empilable, Ombre, 1955  
Contre-plaqué cintré teinté

Chaise Longue  
Bambou



# Italie

**Marco Zanuso**



1951  
fauteuil "Lady"



1954  
fauteuil "Martingala"



**Gio Ponti**

Superleggera Chair

1957

**Carlo Mollino**

1949  
table basse "Arabesco" -  
contreplaqué et verre



1952  
fauteuil "Gilda"



1954  
table en bois pour le restaurant Pavia

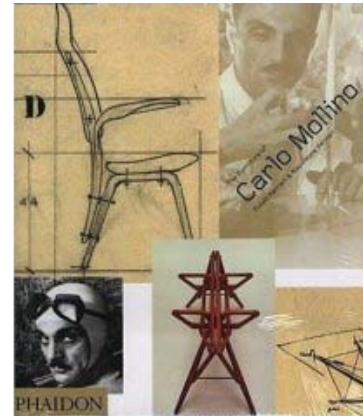

Bibliothèque, 1951



# Finlande

Alvar Aalto



Villa Mairea 1937-1940

Paimio, 1932, Contreplaqué cintré  
Artek



# Eero Saarinen



Tulip chair, 1956



Terminal 5 de l'aéroport international John-F.-Kennedy, 1962

# Danemark

Arne Jacobsen

50'



SAS Royal Hotel, Copenhagen, 1956-61



Chaise fourmi,  
1952

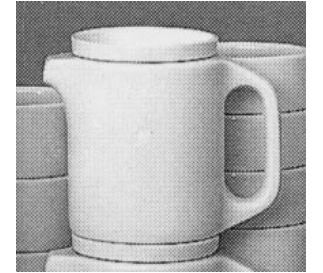

Chaise fourmi,  
1952



Egg and Swan chair,  
1958

# France fonctionnalisme

50'

tradition



**Bureau [CM 141]**Bureau  
Paulin, Pierre  
1954

**Siège d'amphithéâtre** Prouvé, Jean  
1952



**Bibliothèque [Nuage]** Bibliothèque murale  
Perriand, Charlotte  
1954



**Canapé [Boule]**Canapé  
Royère, Jean  
France  
1947



**Buvette Prouvé/Novarina**  
1956

**Module de logement de l'unité  
d'habitation de Marseille**  
connue sous le nom de Cité  
radieuse, 1947-1952

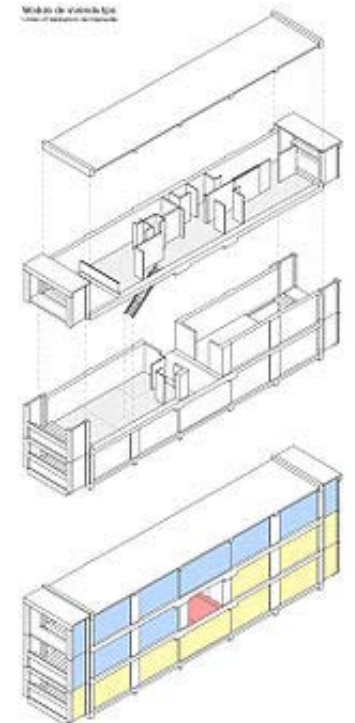



Entre abstraction et figuration

**Informel**



Jean Fautrier, Les tranches d'orange (1944)

**Abstraction lyrique**



Alfred Manessier, Salve Regina 1945

**Paysagisme abstrait**



Nicolas de Staël, Sicile, 1954



Jean Dubuffet, Rocs et broussailles, 1952

**COBRA**



Asger Jorn, Lettre a mon fils, 1956-57

## Land art



Robert Smithson  
Spiral Jetty, 1971

## Art conceptuel



Robert Rauschenberg,  
One and Three chairs 1965

## Minimalisme



Specific object,  
Donald Judd, 1965

## Pop art



Andy Warhol-Marilyn-Monroe's-Lips-1962

## 60'/70'

## Performance



Georges Maciunas,  
Fluxus 1965



Coyote like America and  
America like me  
Josef Beuys, 1974,



Dan Flavin Monument 1  
for Tatlin, 1964



Jasper Johns Trois drapeaux 1958



Soft bathroom tub  
Oldenburg ; 1966

## Arte Povera



Giuseppe Penone  
Albero di cinque metri, 1973

## Op art

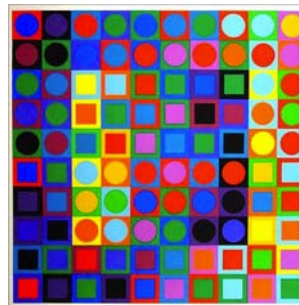

Vasarely  
Folklore Planétaire Participations  
n° 1  
1960



César, Compression, 1960

## Nouveaux réalistes

Yves Klein,  
Anthropométrie  
avec Masculin et  
féminin 1960



## 60'/70' La société de consommation

1959-60  
Panton chair  
Verner Panton  
Danemark



**Design rationnel**  
**« Less is more »**  
Nouveaux matériaux  
Production industrielle  
Fonctionnalisme

1962  
rasoir électrique "Sixtant SM31"  
Hans Gugelot  
Allemagne



1967  
chaise pliante "TS"  
Roger Tallon  
France



1964  
Escalier hélicoïdal  
modules empilables en aluminium  
Roger Tallon

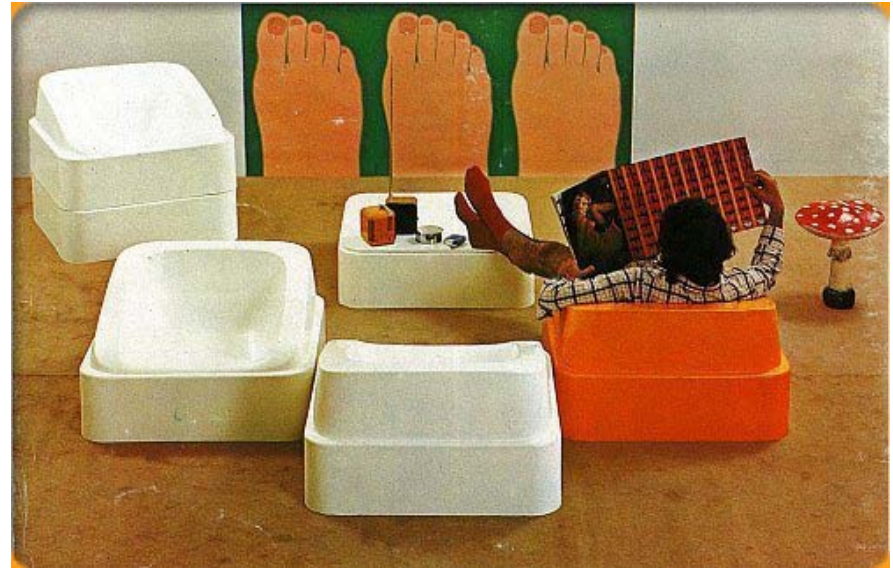

Empilable et peu cher  
les chaînes de  
magasin à prix bas

## 60'/70' Design futuriste

- 1963 Au cinéma : 2001 Odysée de l'espace de Stanley Kubrick



1962  
lampadaire "Arco" –  
base en marbre, acier  
chormé et aluminium  
Achille Castiglioni  
Italie



1967  
lampe "Eclisse"  
Vico Magistretti  
Italie



1968  
Bubble chair  
Eero Aarnio  
Finlande

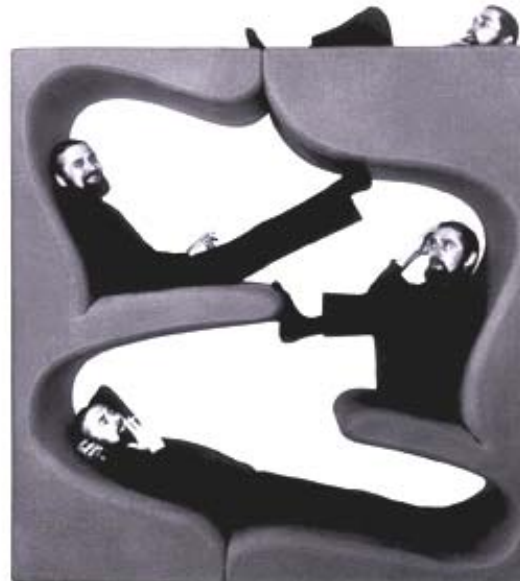

Années 60  
Living sculpture  
Verner Panton  
Danemark

**Les formes enveloppantes  
les coques plastiques**



1967  
fauteuil "Culbuto"  
Marc Held  
France



1963  
fauteuil "Elda 1005"  
Coque en fibre de verre et assise cuir  
Joe Colombo  
Italie

1963  
fauteuil "Globe"  
Eero Aarnio  
Finlande



1969  
machine à écrire "Valentine"  
Ettore Sottsass  
Italie

**60'/70'  
Le plastique**

**Le confort  
la mousse recouverte de tissus jersey**

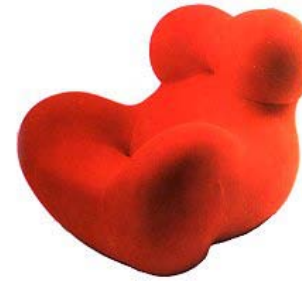

1969  
fauteuil "UP 5 Donna" –  
polyurethane expansé  
Gaetano Pesce  
Italie



1967  
Langue  
Pierre Paulin  
France



1965  
chauffeuse "Djinn"  
Olivier Mourgue

**La technologie**

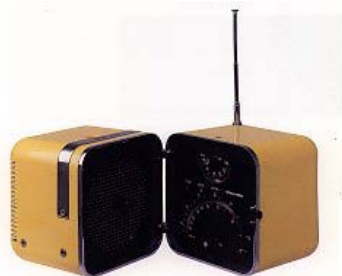

1966  
radio modèle TS502  
Marco Zanuso  
Brionvega  
Italie



1968  
briquet "Cylindric"  
Dieter Rams  
Braun  
Allemagne



1960  
Téléviseur  
Sony  
Japon

**La vie au ras du sol**

1971  
"Pratone"  
mousse de polyurethane  
Gufam  
Italie



1968  
"Sacco" - Sac de vinyle rempli de bille de polystyrène expansé  
Piero Gatti, Cesare Paolini, Franco Teodoro  
Italie, Zanotta



1968  
fauteuil gonflable  
Quasar Khahn  
France



# Architecture de la contestation 60'/70'

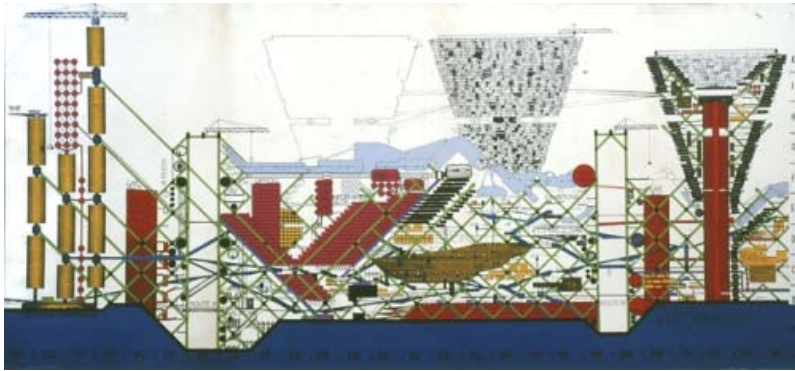

Plugin city, Archigram, 1962, Angleterre

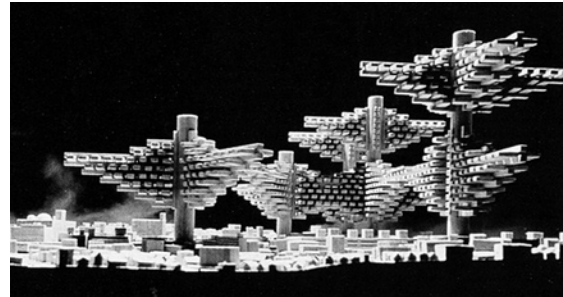

Cluster in the air, Arata Isozaki, Métabolisme, Japon, 1960-62

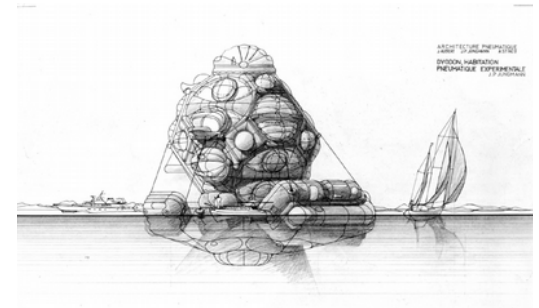

Dyodon, habitation pneumatique, Jean-Paul Jungman, Groupe Utopie, juin 1967, France

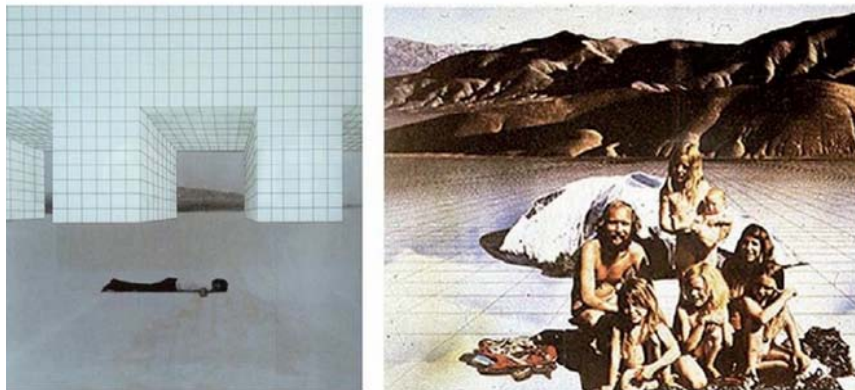

Superstudio, Monument continu, 1969, Italie

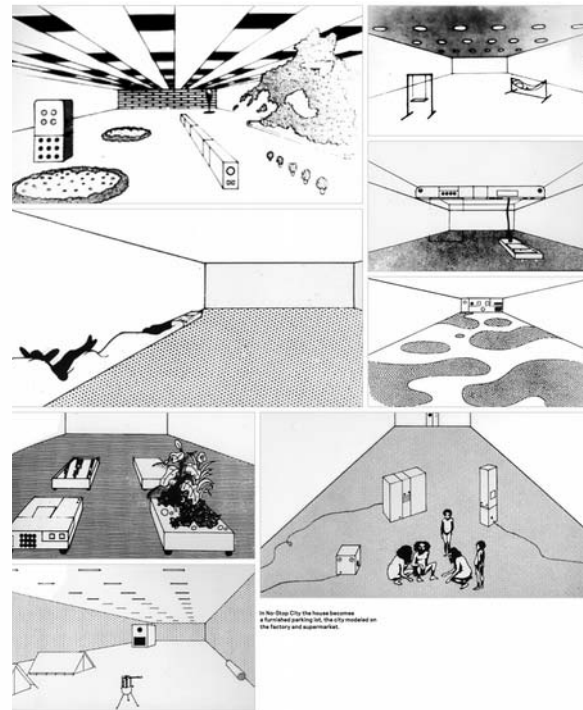

Non stop city, Andréa Branzi, Archizoom, 1969 Italie



Drop city, Colorado 1967



Pierre Szekely, Henri Mouette  
Maison plante Sébourg 1971-73

## L'anti design

70'/80'

## Alchimia

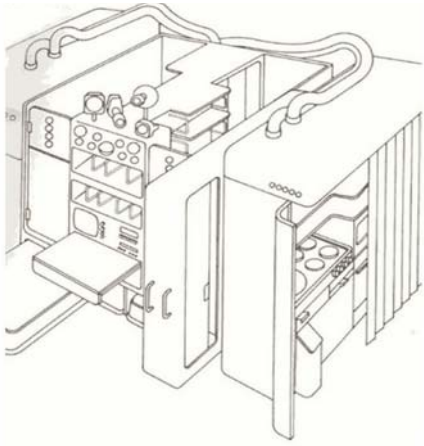

Joe Colombo  
Total furnishing unit, 1969

Ettore Sottsass  
Containers, 1972



Re-design de la Zig zag chair de Rietvelt,  
Alchimia, Alessandro Mendini, 1978

Chair and table for Alchimia,  
Ettore Sottsass, 1979



## Memphis



Peter, Peter Shire, 1987



Bibliothèque Carlton, Ettore Sottsass, 1981



Francis Bacon,  
Trois études pour une  
crucifixion, 1962.



Gerrit Richter Betty-1988



Baselitz Die Mädchen von Olmo 1981



Self Portrait, Basquiat, 1982



# Postmodernisme 80'



La Piazza d'Italia, de Charles Moore, Nouvelle-Orléans, 1978

Alessi

Tea and Coffee Piazza,



Richard Meier

Mickael Graves



1984 Philip Johnson  
AT & T building, New York,

Michaël Graves 1982  
Portland Building



Aldo Rossi

La Conica d'Aldo Rossi

# Déconstructivisme 80'



Peter Eisenman  
La *Guardiola House*

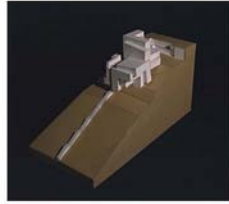

Coop Himmelblau  
*L'Open House*



ZAHA HADID



Vitra Fire Station, Weil am Rhein, Germany (1989-93)



BERNARD TSCHUMI, LES FOLIES DE LA VILLETTE

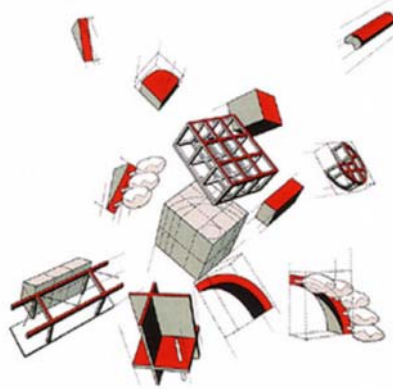

Pour rassembler les différents équipements (Cité des Sciences, Gléde, Zénith, Grande Halle, Cité de la Musique, ...) et jardins à thèmes de la Villette, Bernard Tschumi dissémine des boîtes rouges plus ou moins déconstruites comme autant de folies et deux galeries perpendiculaires. Les folies rouges quadrillent le parc avec chacune sa fonction (restaurant, bureau, ...) et les galeries servent de liaison (une en balcon sur le canal et l'autre lien entre l'avenue Jean Jaurès et l'avenue Corentin Cariou).

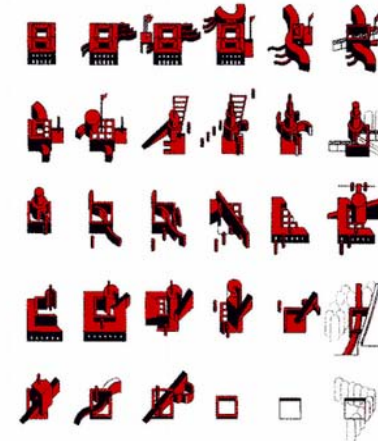
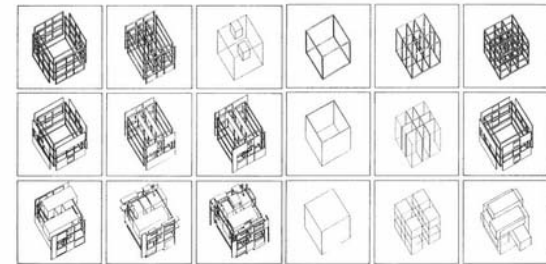

## 90'/2000 les nouvelles attentes des usagers

3 tendances\*

### Classique



Ross Lovegrove

Mobilier de bureau EMMA,  
2000  
Environnement connecté



Supernatural, Polymer Armchair, 2005  
Economiser la matière en s'inspirant de  
la structure alvéolaire des os.

### Maniériste

Philippe Starck



WW stool, Aluminium moulé et laqué, 1991  
Un mobilier sculpture qui vous oblige à  
prendre la pose



Bubu 1er, Polypropylène injecté, 1991,  
entre trône et chaise percée pour  
ranger ses trésors

### Baroque



Gaetano Pesce

Chaise modèle « Broadway », 1992  
acier chromé et résine epoxy  
La série diversifiée



Brillante plus que le soleil, 1992  
procédé Mistral  
Poudre de verre en fusion projetée par  
pistolet sur un moule.  
Production requalifiant le geste de celui  
qui fait

\* C'est moi qui souligne